

Scarifier for heavy duty operations

PTH Ripper

The PTH Ripper is a scarifier that is used to break up path surfaces (concrete, Asphalt, ...) up to 60 cm depth. Larger stones are turned out of the ground by the special PTH kinematic.

The PTH Ripper is the ideal machine to prepare material for a stone crusher. The PTH Ripper impresses with its release mechanism, which prevents damage and avoids high loads on the device and tractor.



min. 120 HP



Standard features

- + Full frame construction
- + 7 tine arms with excavator teeth (CAT), interchangeable
- + PTH release mechanism to turn and loosen rocks
- + Swing arm mounts made of special cast iron
- + Reinforced coil springs for wear-free work
- + Integrated toolbox

Technical specification

Power requirement	from 120 HP
Dead weight	approx. 1700 kg
Working width	2.300 mm
Overall width	2.400 mm
Number of tines	7
Working depth	up to 600 mm

Special equipment

- o LED lighting
- o Height guidance
- o Special paint according to RAL specification
- o customized number of tines for wine and fruit growing
- o XXL version for heavy road construction



PTH Ripper

Integrated lockable
Toolbox

mounting
KAT. 2

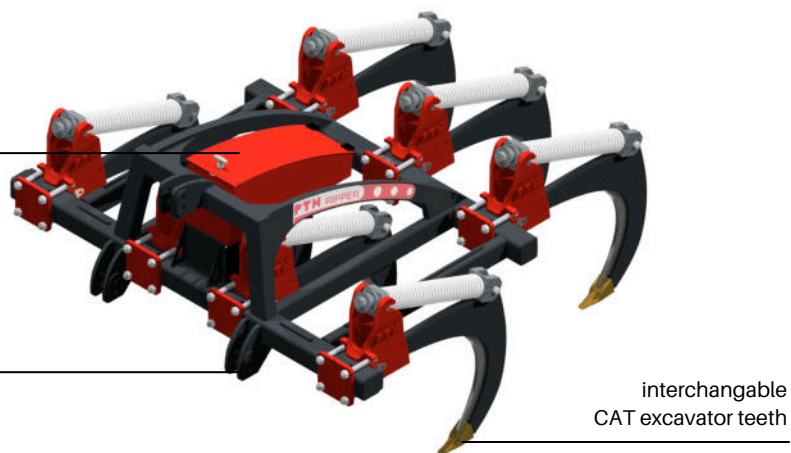

interchangeable
CAT excavator teeth

full frame
construction

optional
LED lighting

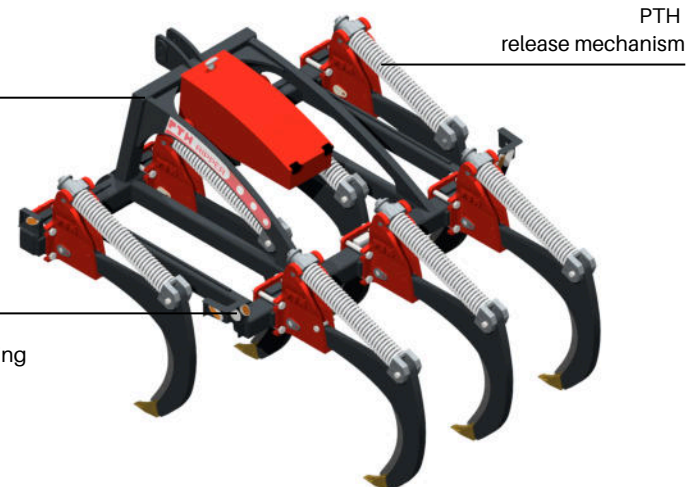

PTH
release mechanism